

TCB22 Series

TCB22/22M | TCB22C/22MC

Heavy Duty Cutting CNC Turning Center

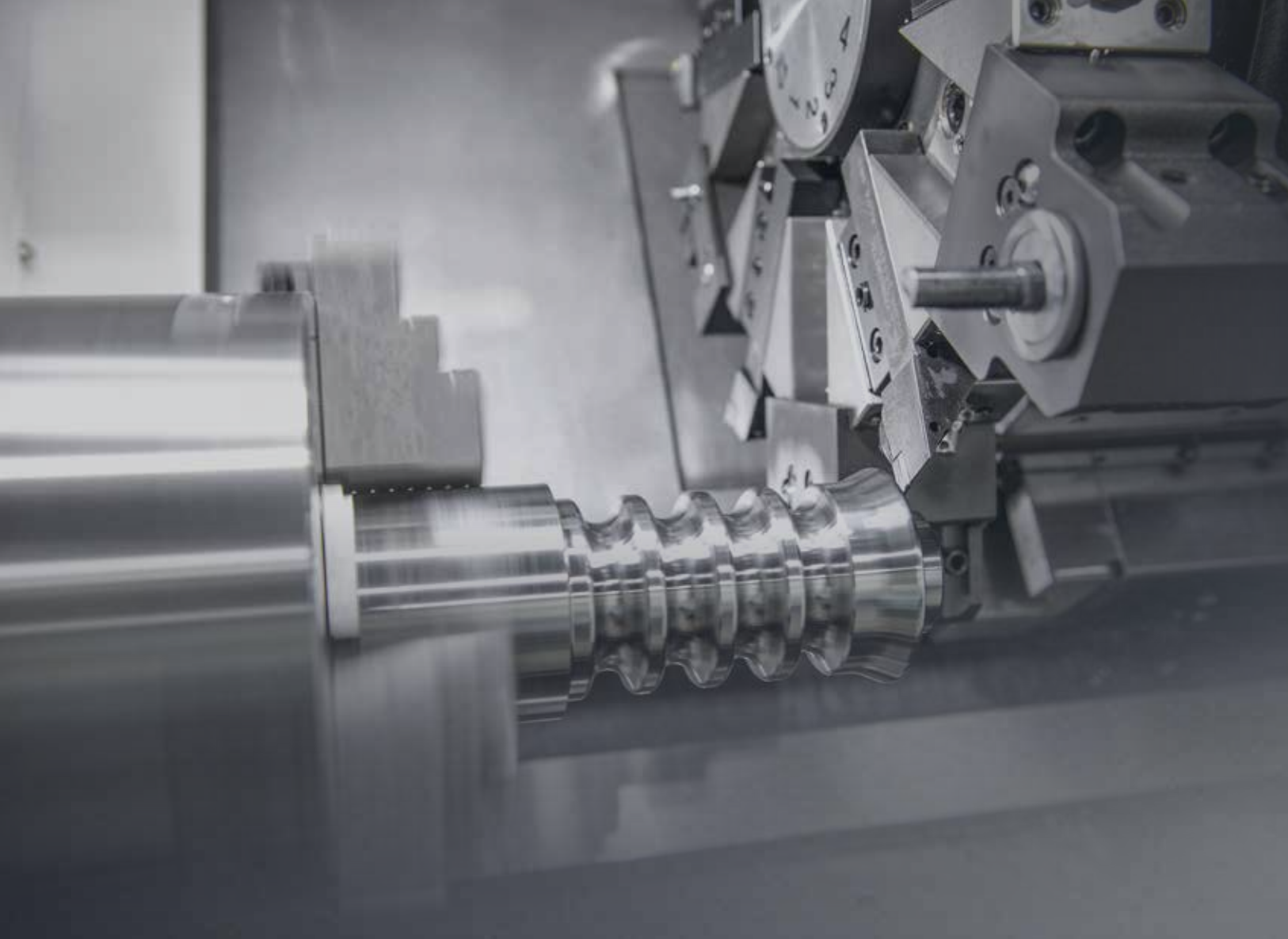

Technical Leader

The CNC Turning Center TC22 Series, designed by SG WIA with years of expertise and the latest technology, is a Turning Center that maximizes productivity and performance.

		TC22 TC22C	TC22M TC22MC
Max. Swing	mm(in)	Ø550 (21.7")	Ø550 (21.7")
Max. Turning Length	mm(in)	565 (22.2") 550 (21.7")	467 (18.4") 452 (17.8")
Chuck Size	inch	8" [10"] 10"	8" [10"] 10"
Bar Capacity	mm(in)	Ø65 (2.6") Ø81 (3.2")	Ø65 (2.6") Ø81 (3.2")
Spindle Speed (rpm)	r/min	4,500 [4,000] [4,000] 3,500	4,500 [4,000] [4,000] 3,500 [3,500]
Spindle Motor (Max.)	kW(HP)	18.5 (24.8) [18.5 (24.8)] [23.6 (31.6)] 18.5 (24.8)	18.5 (24.8) [18.5 (24.8)] [23.6 (31.6)] 18.5 (24.8) [26.4 (35.4)]
Travel (X/Z)	mm(in)	215/580 (8.5"/22.8")	215/482 (8.5"/19.1")
No. of Tools	EA	12	12

- Box guideways for heavy duty cutting
- 45° slanted one-piece bed structure for high rigidity
- Stabilized Unit Structure to minimize thermal displacement
- User convenient structure for high productivity
- Excellent rapid traverse rate: 30m/min [1,181ipm] (Z-axis)
- Reliable, high speed servo turret: 0.12sec/step
- Ergonomic design for convenient access to chuck and tool



01 BASIC STRUCTURE

High Productivity 8/10 inch CNC Turning Center for Heavy Duty Cutting

Mill Turret ('M' Type)

- BMT55P (12 Station)
- 6,000 r/min
- Collet Size : $\varnothing 16$ ($\varnothing 5/8$ ") {ER25}

Tail Stock

- MT#4 [MT#5]
- Quill Dia. : $\varnothing 65$ (2.6")
[Opt. $\varnothing 100$ (3.9")]

High Precision Spindle

- Integral body & heat dissipating RIB structure.
- TC22/22M : 8" [10"]
- TC22C/22MC : 10"
- C-Axis Control : 0.001° ('M' Type)

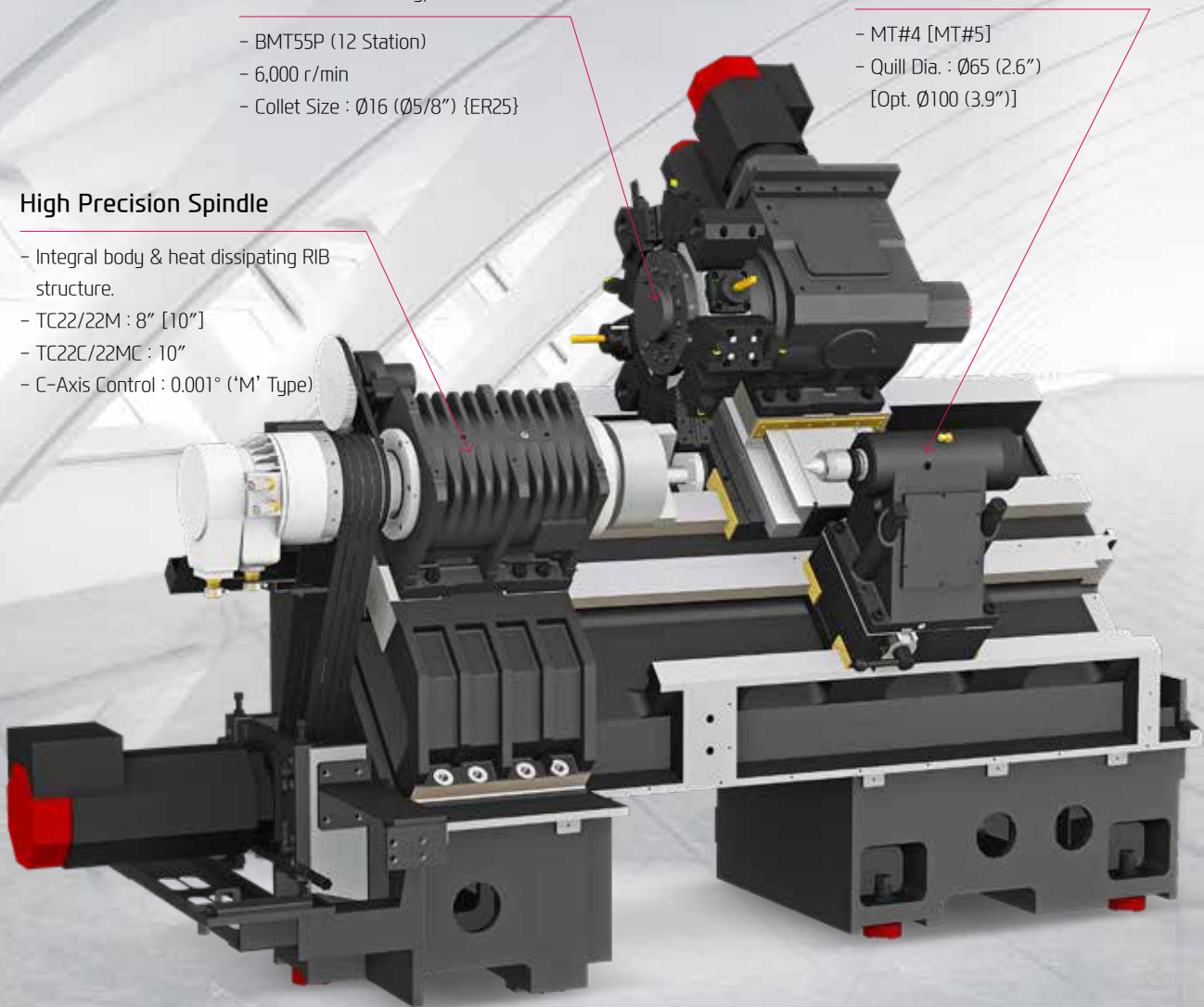

POWERFUL CUTTING CAPABILITY & WIDE CUTTING AREA

ALL-IN-ONE TYPE OF BED

High Rigidity, One-Piece Structure

The bed structure of the TC22 is designed with combination of square type and tubular rib structure. It has a slope of 45 ° which helps maintain high rigidity. It shows great performance in heavy duty cutting, absorbing vibration and maintaining accuracy.

Integrated Coolant Tank

The coolant tank is installed at the front of the bed to prevent leakage, enabling stable machining with the use of high pressure coolant.



GUIDEWAY

Box Guideway

All axis of TC22 are designed with Box Guideways for better travel ability. Box Guideways show great performance in offsetting vibrations caused by heavy duty cutting.

Sealed GIB Structure

X-axis of TC22 is designed to minimize the damage of turcite from chips by applying the sealed GIB structure.

Z-Axis High Performance Motor

Z-axis feed ability is improved by installing high performance servo motor.

(Z-axis Rapid Traverse Rate : 30 m/min [1,181 ipm])



Rapid Traverse Rate (X/Z)	TC22/C Travel (X/Z)	TC22M/MC Travel (X/Z)
24/30 m/min (945/1,181 ipm)	215/580 mm (8.5"/22.8")	215/482 mm (8.5"/19")

02 HIGH PRECISION SPINDLE

Long Lasting, High Accuracy & Excellent Performance CNC Turning Center

Spindle Specifications

[] : Option

ITEM	Spindle Speed	Motor (Max./Cont.)	Torque (Max./Cont.)	Controller
TC22/M	4,500 rpm	18.5/15 kW (25/20 HP)	206/125.3 N·m (151.9/92.4 lbf·ft)	FANUC
	[4,000 rpm (High-torque)]	[18.5/15 kW (25/20 HP)]	353.2/214.8 N·m (260.5/158.4 lbf·ft)	
	[4,000 rpm]	[23.6/15 kW (31.6/20 HP)]	[224.9/143.2 N·m (166/105.6 lbf·ft)]	SIEMENS
TC22C	3,500 rpm	18.5/15 kW (25/20 HP)	403.6/245.4 N·m (297.7/181 lbf·ft)	FANUC
TC22MC	3,500 rpm	18.5/15 kW (25/20 HP)	403.6/245.4 N·m (297.7/181 lbf·ft)	FANUC
	[3,500 rpm]	[26.4/22 kW (35.4/30 HP)]	[428.4/357 N·m (314/263.3 lbf·ft)]	SIEMENS

HEAVY DUTY CUTTING & HIGH ACCURACY

SPINDLE

Spindle for Heavy Cutting

The main spindle is designed with the same structure as that often found in larger sized machines. The combination of double cylindrical roller bearings and angular contact ball bearings leads to excellent heavy duty cutting performance.

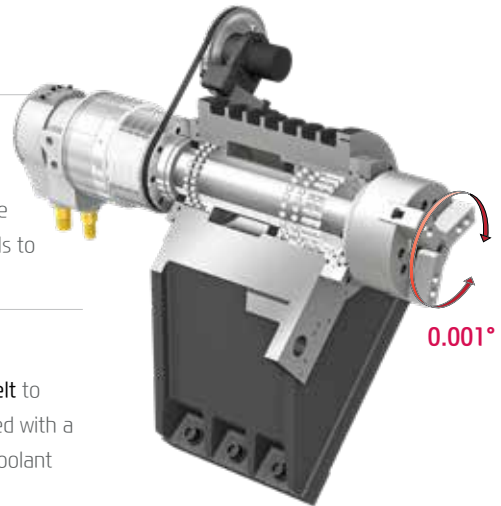

Ribstar Belt

Also, machining performance is enhanced by applying ribstar belt to minimize noise and belt slipping problems. The spindle is designed with a labyrinth structure to minimize possible bearing damage from coolant and to improve machining stability.

C-Axis Control ('M' Type)

C-axis of TC22 Series can be controlled to 0.001° which makes it possible to process various shapes.

TAIL STOCK

[] : Option

MT#4 Tail Stock

Tailstock enables stable machining of high quality products where quill travels up to 80mm (3"). (MT#5 Tail Stock : Option)

- ◎ Quill Dia. : **Ø65** (2.6") [MT#5 : Ø100 (3.9")]
- ◎ Quill Travel : **80** mm (3") [MT#5 : 120 mm (4.7")]
- ◎ Tail Stock Travel : **513.7** mm (20.2")



03 SERVO TURRET

High speed, High Accuracy, Highly Reliable Servo Turret



Servo Turret

No. of Tools	Tool Size (O.D/I.D)	Indexing Time
12 ^{EA}	□ 25/Ø40 mm (□ 1"/Ø1 1/2")	0.12 sec

Mill Turret

[] : Option

ITEM	Speed	Motor (Max./Cont)	Torque (Max./Cont)	Collet Size
BMT55P (FANUC)	6,000 rpm	5.5/3.7 kW (7.5/5 HP)	52.5/26.5 N·m (38.7/19.5 lbf-ft)	Ø16 (0.6") /ER25
BMT55P (SIEMENS)	[6,000 rpm]	[5.3/2.8 kW (7.1/3.8 HP)]	[51/26.8 N·m (37.6/19.8 lbf-ft)]	

VARIOUS DRIVEN PRECISION BMT TOOL HOLDERS

SERVO TURRET

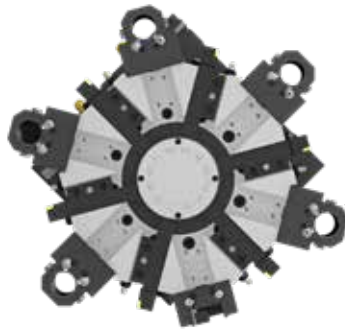

TC22/C Servo Turret

The turret of TC22 is applied with high performance AC servo motor, improving machining reliability. 3-piece coupling shows excellent performance in indexing. Powerful hydraulic tool clamping minimizes tool tip deviation caused by load.

Holder

To enhance rigidity, M10 bolts are used to fix holders and M12 bolts are used to fix boring bar holders.

20 Bar(290 psi) High Pressure Coolant **OPTION**

Turret is designed to utilize 20 bar (290 psi) high pressure coolant and it shows optimum performance in machining difficult-to-cut material.



MILL TURRET

TC22M/MC BMT55P Turret (Mill Turret)

The BMT turret secures the tool with four bolts and key on the tool mounting surface of the turret, making it possible to powerfully fix the tool, ensuring high reliability in rigidity and precision.



STRAIGHT MILLING HEAD



ANGULAR MILLING HEAD



Mill Tool Holder

Machining capability has increased with the addition of straight milling head tool holder, which can machine workpieces from the side, and angular milling head tool holder, which can perform I.D. operations.



Special Tool

OPTION

The TC22 series can process high value-added products using a variety of rotating tools. In particular, there is a multi-holder for attaching a variety of tools to one holder, and an eccentric rotary tool for handling eccentric parts without additional axis travel, which can realize integration of process with one machine.

❖ Consultation needed when ordering these options.

04 USER CONVENIENCE

Various Devices for User Friendly

BAR FEEDER SYSTEM



Bar Feeder

Bar feeder system enables automation which leads to efficiency improvement.

	<p>Parts Catcher An optional parts catcher collects finished parts without the need to open the door, adding productivity, especially when a bar feeder is attached.</p>		<p>Auto Door Using M-code, the doors can be automatically opened and closed which brings productivity and convenience for automation.</p>
	<p>Parts Conveyor The parts conveyor transfers the finished workpiece unloaded by the parts catcher for user convenience.</p>		<p>Auto Shutter Using auto shutter, automation system with gantry loader is possible without opening the machine's door.</p>

GANTRY LOADER SYSTEM

Gantry Loader Machining Process

The high speed gantry loaders and the work stocker allow the implementation of automation cells. This enables flexible machining process and productivity enhancement. Optimization of the installation space is also possible.

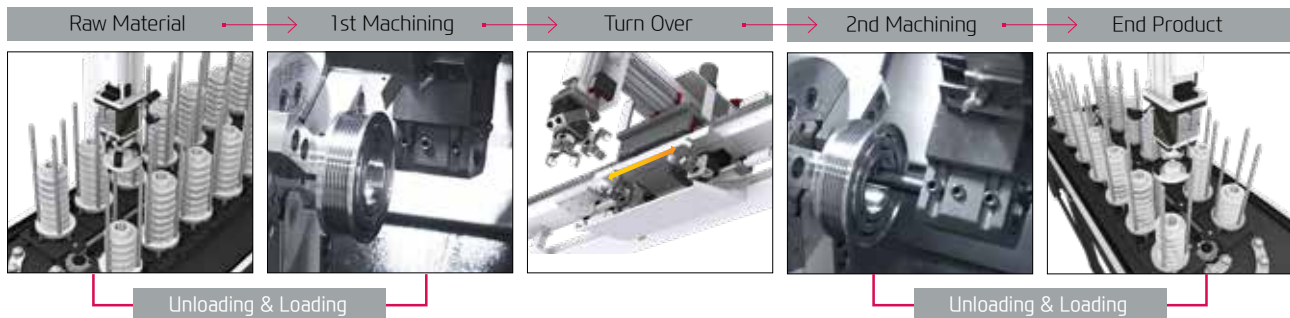

Optional

CHIP DISPOSAL SOLUTION

Timely and effective disposal of chips will enhance productivity as well as the working environment.



Hinge	Chip Type : Roughing Chip, Long Chip, Chip complex	Material : SS41, 45C, Cast Steel	Front-Right Direction
	Highly efficient when disposing a lot of chips. Capable of handling stringy chips..		
Scraper	Chip Type : Finely broken chip blown out	Material : cast Iron, Nonferrous	
	Convenient for shortly cut chips.		
❖ Drum Filter	Chip Type : Powder, Micro Chip	Material : AL	
	Advantageous in precision, as the chips do not flow in to the coolant nozzle.		

❖ When ordering a drum filter chip conveyor, prior consult with hyundai wia's sales person.

HIGH PRECISION SYSTEM & COOLANT UNIT



Automatic Q-Setter



Linear Scale



Work Probe



Standard Coolant (Nozzle)



Chuck Coolant (Upper Chuck)



Chuck Air Blow (Upper Chuck)

05 FANUC – Smart Plus

The Compatible All-round Control



15" Touch-type Monitor as a standard



Fast Cycle Time Technology	Smart Machine Control	Fine Surface Technology
Smart Servo Control Technology	Conversational Program	SmartGuide-i
Machining-aid Function	i-HMI	5120M (2MB)
No. of Registerable Programs 1000 EA	Part Program Storage	

Servo Learning Oscillation Function for ChipBreaking **OPTION**

- Machining Method : he tool cuts the workpiece moving in a zigzag pattern. (Oscillating) → Air cut section occurs → Long chips break
- Advantage : Increase tool life, Enhance surface finishing, Improve chip disposal
- Machine : All turning centers with FANUC controller (Option)

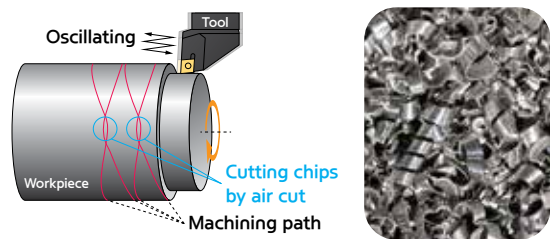

(Developed special screen page for servo learning oscillation function / Even when this function is applied, the cycle time remains same.)

MMS (Machine Monitoring System)

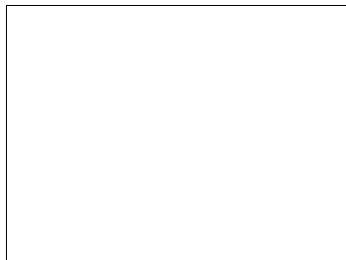
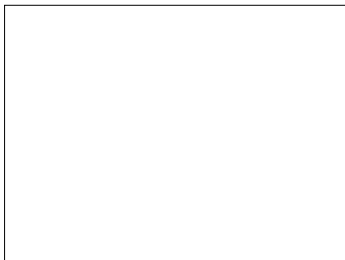

MMS Cloud

A cloud server-based equipment monitoring system for collecting and analyzing facility operation data.

Manufacturing big data solution with design, manufacturing, and intelligence technology of SG-WIA
(Big data collection/Analysis/Visualization)

SMART CNC (FANUC Smart Plus)



1. Dialogue Program (Smart Guide-i)

This software offers the maximum user convenience through dialogue manipulation from setup to processing. This includes writing processing programs and simulation checks.

2. LAUNCHER

This software offers shortcuts for quick access to specialized features and frequently used features.

SPECIFICATIONS

Standard & Optional

● : Standard ○ : Option ☆ : Prior Consultation - : Non Applicable

Spindle		TC22	TC22C
Main Spindle	8"	●	-
Hollow Chuck 3 Jaw	10"	○	●
Main Spindle	8"	-	-
Solid Chuck 3 Jaw	10"	-	-
Standard Soft Jaw (1set)		●	●
Chuck Clamp Foot Switch		●	●
2 Steps Hyd. Pressure Device		○	○
Spindle Inside Stopper		☆	☆
5° Index		☆	☆
Cs-Axis (0.001°)		-	-
Chuck Open/Close Confirmation Device		●	●
2 Steps Chuck Foot Switch		○	○
Turret			
Tool Holder		●	●
Mill Turret	BMT	-	-
Straight Milling Head	Collet Type, 1ea	-	-
Angular Milling Head	Collet Type, 1ea	-	-
Straight Milling Head	Adapter Type	-	-
Angular Milling Head	Adapter Type	-	-
Boring Sleeve		●	●
Drill Socket		●	●
U-Drill Holder		○	○
U-Drill Holder Sleeve		○	○
O.D Extension Holder	For Out-Dia	○	●
Angle Head		-	-
Tail Stock & Steady Rest			
Quill Type Tail Stock	MT#4 (Ø65(Ø2.6))	●	●
	MT#4 (Ø80(Ø3.1))	○	○
	MT#5 (Ø100(Ø3.9))	○	○
Programmable Tail Stock	MT#4 (Ø65(Ø2.6))	○	○
	MT#4 (Ø80(Ø3.1))	○	○
Built-in Tail Stock	MT#4 (Ø100(Ø3.9))	○	○
Manual Type Hyd. Steady Rest		-	-
Standard Live Center (Tail Stock : Standard)		●	●
High Precision Live Center		-	-
2 Steps Tail Stock Pressure System		☆	☆
Quill Forward/Reverse Confirmation Device		○	○
Tail Stock Foot Switch		☆	☆
Coolant & Air Blow			
Standard Coolant (Nozzle)		●	●
Chuck Coolant (Upper Chuck)		○	○
Gun Coolant		○	○
Through Spindle Coolant (Only for Special Chuck)		☆	☆
Chuck Air Blow (Upper Chuck)		○	○
Tail Stock Air Blow (Upper Tail Stock)		○	○
Turret Air Blow		☆	☆
Air Gun		○	○
Through Spindle Air Blow (Only for Special Chuck)		-	-
High Pressure Coolant	0.5Bar	●	●
	6Bar	○	○
	20Bar	○	○
Power Coolant System (For Automation)		☆	☆
Coolant Chiller (Only for Sub Tank, Chip Conveyor)		-	-
Chip Disposal			
Coolant Tank	150 ℓ (39.6gal)(Side)	●	●
	180 ℓ (47.6gal)(Side)	● (Only for High Pressure Coolant 20 bar)	
	210 ℓ (55.5gal)(Rear)	○	○
Chip Conveyor (Hinge/Scraper)	Front (Right)	○	○
	Rear (Rear)	○	○
Special Chip Conveyor (Drum Filter)		-	-
Chip Wagon	Standard (180 ℓ [47.5 gal])	○	○
	Swing (200 ℓ [52.8 gal])	○	○
	Large Swing (290 ℓ [76.6 gal])	○	○
	Large Size (330 ℓ [87.2 gal])	○	○
	Customized	☆	☆

Safety Device		TC22	TC22C
Total Splash Guard		●	●
Back Spin Torque Limiter (BST)		●	●
Chuck Hydraulic Pressure Maintenance Interlock		☆	☆
Electric Device			
Call Light	1Color : ●	●	●
Call Light & Buzzer	3Color : ● ● ● B	○	○
Electric Cabinet Light		○	○
Remote MPG		○	○
Work Counter	Digital	○	○
Total Counter	Digital	○	○
Tool Counter	Digital	○	○
Multi Tool Counter	Digital	○	○
Electric Circuit Breaker	FANUC	○	○
	SIEMENS	-	-
AVR (Auto Voltage Regulator)		☆	☆
Transformer	25kVA	○	○
Auto Power Off		○	○
Measurement			
Manual Q-Setter		○	○
Manual Q-Setter (Renishaw)		○	○
Automatic Q-Setter (Renishaw)		○	○
Work Close Confirmation Device (Only for Special Chuck)	TACO	○	○
	SMC	○	○
Auto Tool Measuring Device		○	○
Linear Scale	X/Z Axis	-	-
Coolant Level Sensor (Only for Chip Conveyor, bladder Type)		☆	☆
Environment			
Air Conditioner		○	○
Oil Mist Collector		☆	☆
Oil Skimmer (Only for Chip Conveyor)		○	○
MQL (Minimal Quantity Lubrication)		☆	☆
Fixture & Automation			
Auto Door		○	○
Auto Shutter (Only for Automatic System)		○	○
Sub Operation Pannel		☆	☆
Bar Feeder Interface		○	○
Bar Feeder		☆	☆
Workpusher (Spring type)		○	○
Extra M-Code 4ea		○	○
Automation Interface		☆	☆
I/O Extension (IN & OUT)	16 Contact	○	○
	32 Contact	○	○
Parts Catcher	Main SP.	○	○
Turret Work Pusher (For Automation)		☆	☆
Parts Conveyor (Required Main Parts Catcher)		☆	☆
Semi Automation System		☆	☆
Hyd. Device			
Standard Hyd. Cylinder	Hollow	●	●
Standard Hyd. Unit	35bar/15 ℓ (4gal)	●	●
S/W			
Dialogue Program (HW-DPRO)		○	○
DNC software (HW-eDNC)		○	○
Machine Monitoring System (HW-MMS Cloud)		☆	☆
Smart Guide-i : FANUC		●	●
Smart S/W		☆	☆
ETC			
Tool Box		●	●
Customized Color	Need Munsell No.	☆	☆
CAD & CAM		☆	☆

❖ 4 channel of TDC(Thermal Displacement Compensation) device is recommended, when more than 6 bar of high pressure coolant is applied, for the high quality machining. Specifications are subject to change without notice for improvement. / Please refer to the S/W catalog (iRIS) for details by S/W product.

SPECIFICATIONS

Standard & Optional

Spindle		TC22M	TC22MC
Main Spindle	8"	●	-
Hollow Chuck 3 Jaw	10"	○	●
Main Spindle	8"	-	-
Solid Chuck 3 Jaw	10"	-	-
Standard Soft Jaw (1set)		●	●
Chuck Clamp Foot Switch		●	●
2 Steps Hyd. Pressure Device		○	○
Spindle Inside Stopper		☆	☆
5° Index		☆	☆
Cs-Axis (0.001")		●	●
Chuck Open/Close Confirmation Device		●	●
2 Steps Chuck Foot Switch		○	○
Turret			
Tool Holder		●	●
Mill Turret	BMT	●	●
Straight Milling Head	Collet Type,1ea	●	●
Angular Milling Head	Collet Type,1ea	●	●
Straight Milling Head	Adapter Type	○	○
Angular Milling Head	Adapter Type	○	○
Boring Sleeve		●	●
Drill Socket		○	○
U-Drill Holder		●	●
U-Drill Holder Sleeve		●	●
O.D Extension Holder	For Out-Dia	-	-
Angle Head		☆	☆
Tail Stock & Steady Rest			
Quill Type Tail Stock	MT#4 (Ø65(Ø2.6))	●	●
	MT#4 (Ø80(Ø3.1))	○	○
	MT#5 (Ø100(Ø3.9))	○	○
Programable Tail Stock	MT#4 (Ø65(Ø2.6))	○	○
	MT#4 (Ø80(Ø3.1))	○	○
Built-in Tail Stock	MT#4 (Ø100(Ø3.9))	○	○
Standard Live Center (Tail Stock : Standard)		●	●
High Precision Live Center		-	-
2 Steps Tail Stock Pressure System		☆	☆
Quill Forward/Reverse Confirmation Device		○	○
Tail Stock Foot Switch		☆	☆
Coolant & Air Blow			
Standard Coolant (Nozzle)		●	●
Chuck Coolant (Upper Chuck)		○	○
Gun Coolant		○	○
Through Spindle Coolant (Only for Special Chuck)		☆	☆
Thru Coolant for Live Tool		○	○
Chuck Air Blow (Upper Chuck)		○	○
Tail Stock Air Blow (Upper Tail Stock)		○	○
Turret Air Blow		☆	☆
Air Gun		○	○
Through Spindle Air Blow (Only for Special Chuck)		-	-
High Pressure Coolant	0.5Bar	●	●
	6Bar	○	○
	20Bar	○	○
Power Coolant System (For Automation)		☆	☆
Coolant Chiller (Only for Sub Tank, Chip Conveyor)		-	-
Chip Disposal			
Coolant Tank	150 ℓ (39.6gal)(Side)	●	●
	180 ℓ (47.6gal)(Side)	● (Only for High Pressure Coolant 20 bar)	
	210 ℓ (55.5gal)(Rear)	○	○
Chip Conveyor (Hinge/Scraper)	Front (Right)	○	○
	Rear (Rear)	○	○
Special Chip Conveyor (Drum Filter)		-	-
Chip Wagon	Standard (180 ℓ [47.5 gal])	○	○
	Swing (200 ℓ [52.8 gal])	○	○
	Large Swing (290 ℓ [76.6 gal])	○	○
	Large Size (330 ℓ [87.2 gal])	○	○
	Customized	☆	☆

● : Standard ○ : Option ☆ : Prior Consultation - : Non Applicable

Safety Device		TC22M	TC22MC
Total Splash Guard		●	●
Back Spin Torque Limiter (BST)		●	●
Chuck Hydraulic Pressure Maintenance Interlock		☆	☆
Electric Device			
Call Light	1Color : ●	●	●
Call Light & Buzzer	3Color : ● ● ● B	○	○
Electric Cabinet Light		○	○
Remote MPG		○	○
Work Counter	Digital	○	○
Total Counter	Digital	○	○
Tool Counter	Digital	○	○
Multi Tool Counter	Digital	○	○
Electric Circuit Breaker	FANUC	○	○
	SIEMENS	-	-
AVR (Auto Voltage Regulator)		☆	☆
Transformer	25kVA	○	○
Auto Power Off		○	○
Measurement			
Manual Q-Setter		○	○
Manual Q-Setter (Renishaw)		○	○
Automatic Q-Setter (Renishaw)		○	○
Work Close Confirmation Device (Only for Special Chuck)	TACO	○	○
	SMC	○	○
Auto Tool Measuring Device		○	○
Linear Scale	X/Z Axis	-	-
Coolant Level Sensor (Only for Chip Conveyor, bladder Type)		☆	☆
Environment			
Air Conditioner		○	○
Oil Mist Collector		☆	☆
Oil Skimmer (Only for Chip Conveyor)		○	○
MQL (Minimal Quantity Lubrication)		☆	☆
Fixture & Automation			
Auto Door		○	○
Auto Shutter (Only for Automatic System)		○	○
Sub Operation Pannel		☆	☆
Bar Feeder Interface		○	○
Bar Feeder		☆	☆
workpusher (Spring type)		○	○
Extra M-Code 4ea		○	○
Automation Interface		☆	☆
I/O Extension (IN & OUT)	16 Contact	○	○
	32 Contact	○	○
Parts Catcher		○	○
Turret Work Pusher (For Automation)		☆	☆
Parts Conveyor (Required Main Parts Catcher)		☆	☆
Semi Automation System		☆	☆
Hyd. Device			
Standard Hyd. Cylinder	Hollow	●	●
Standard Hyd. Unit	35bar/15 ℓ (4gal)	●	●
S/W			
Dialogue Program (HW-DPRO)		○	○
DNC software (HW-eDNC)		○	○
Machine Monitoring System (HW-MMS Cloud)		☆	☆
Smart Guide-i : FANUC		●	●
Smart S/W		☆	☆
ETC			
Tool Box		●	●
Customized Color	Need Munsel No.	☆	☆
CAD & CAM		☆	☆

❖ 4 channel of TDC(Thermal Displacement Compensation) device is recommended, when more than 6 bar of high pressure coolant is applied, for the high quality machining.

Specifications are subject to change without notice for improvement. / Please refer to the S/W catalog (IRIS) for details by S/W product.

SPECIFICATIONS

Spindle Output/Torque Diagram (FANUC)

TC22/M 4,500rpm

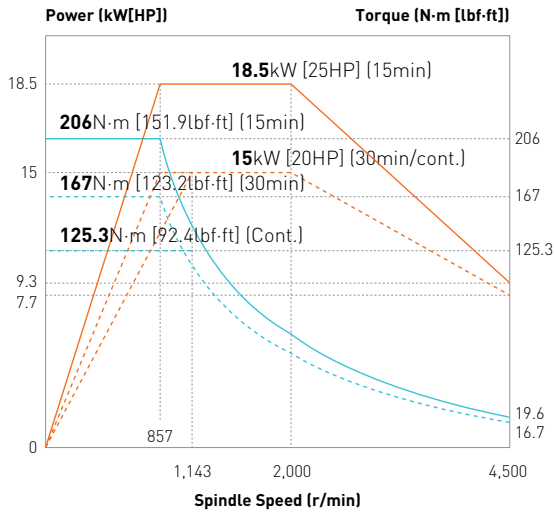

TC22/M 4,000rpm (High-Torque)

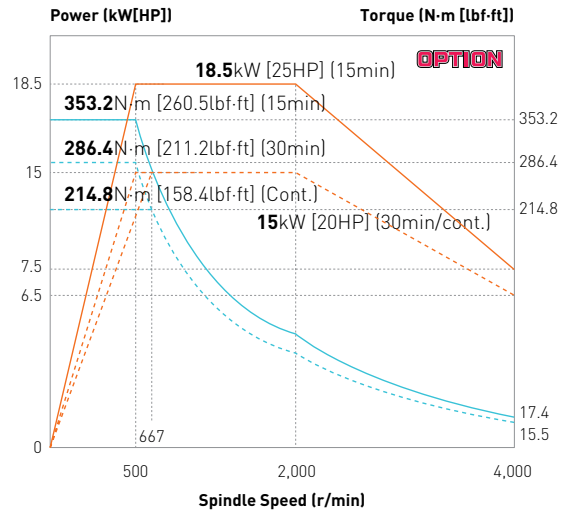

TC22C/MC 3,500rpm

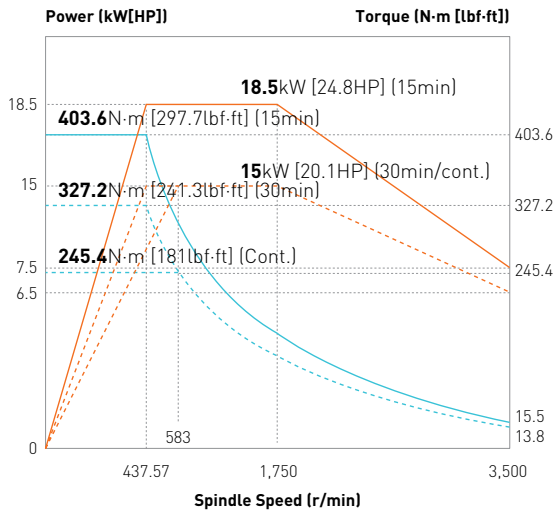

BMT55 6,000 rpm

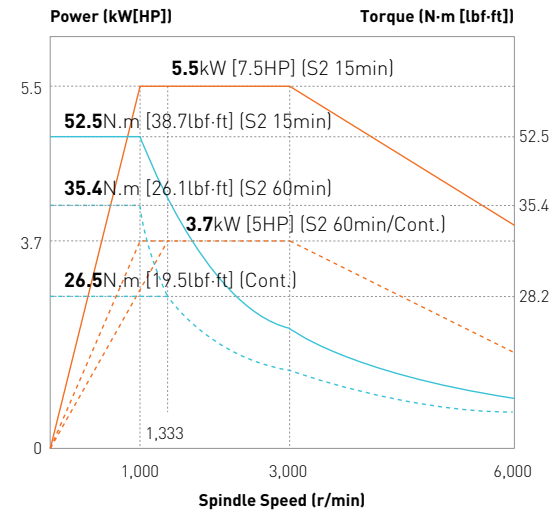

SPECIFICATIONS

Spindle Output/Torque Diagram (SIEMENS)

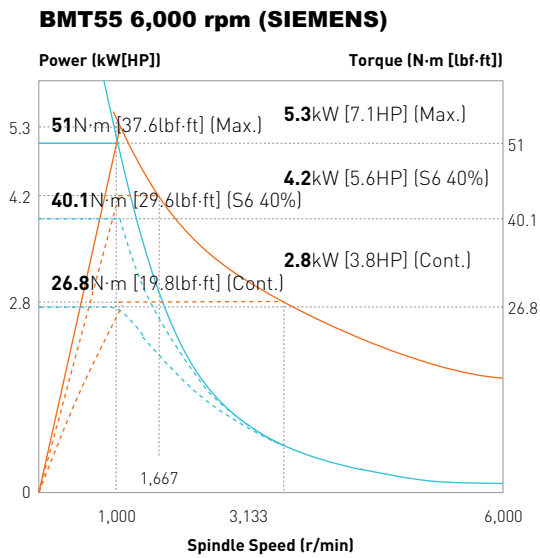
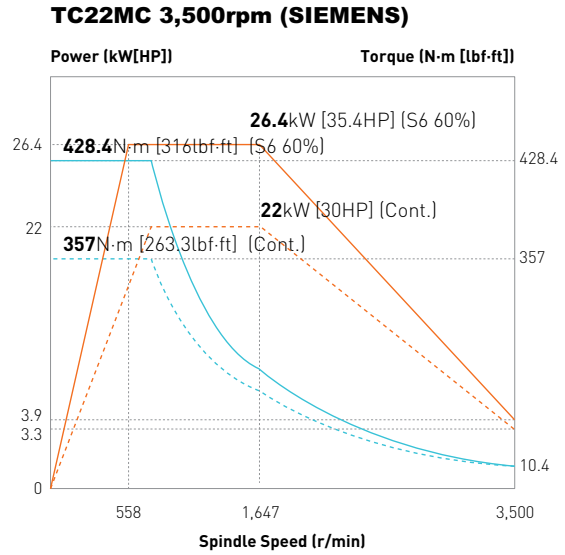
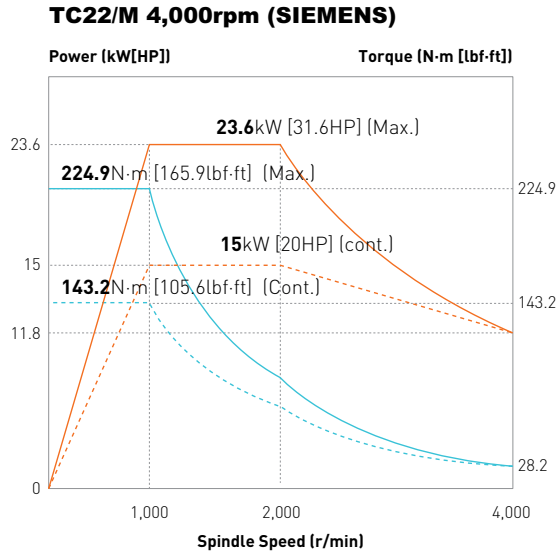

SPECIFICATIONS

External Dimensions

unit : mm(in)

TC22/M
TC22C/MC

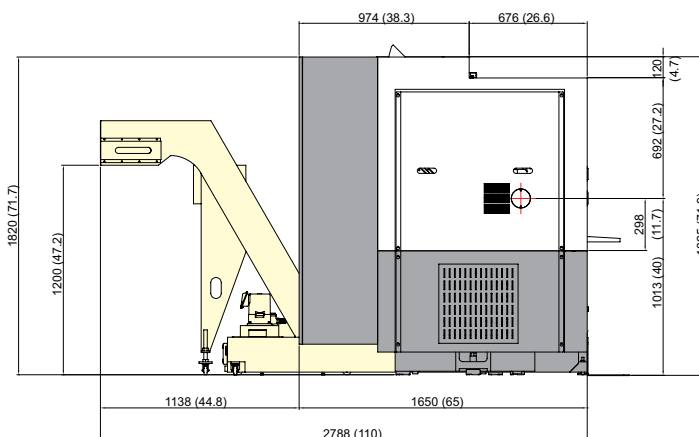
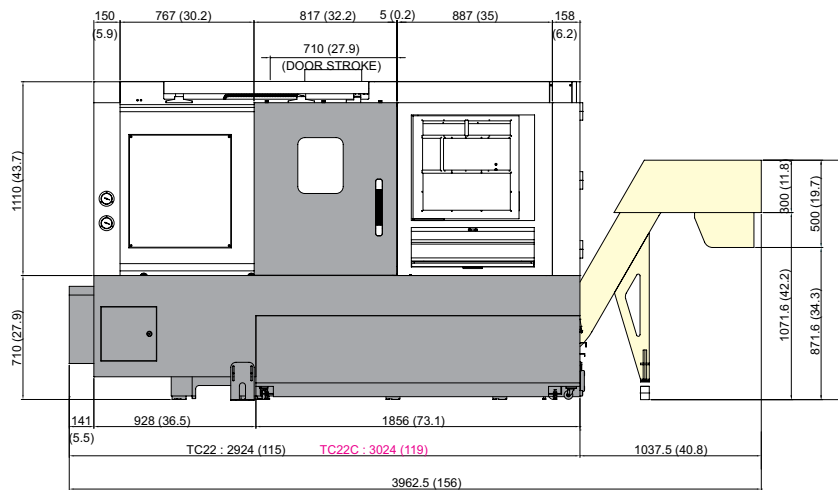
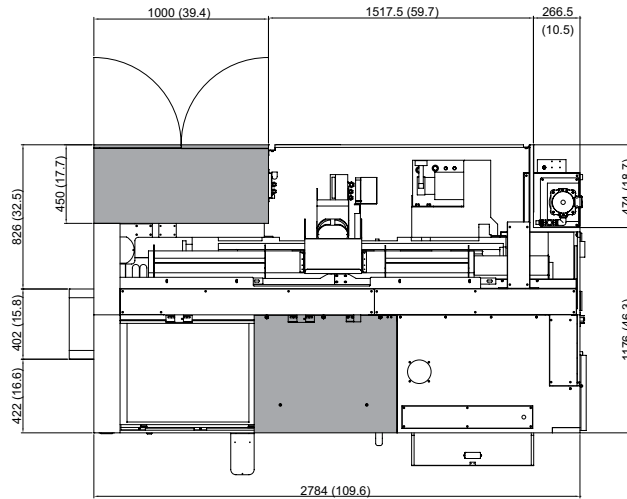

SPECIFICATIONS

Tooling System

unit : mm(in)

TC22 | TC22C

 Option

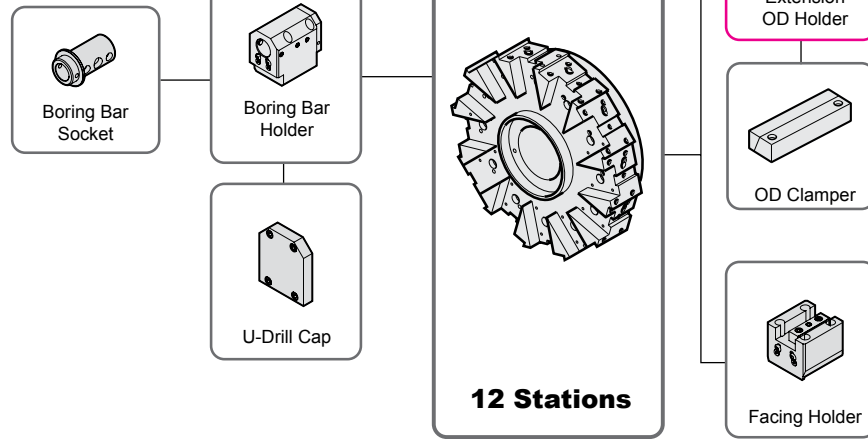

Tooling Parts Detail

ITEM			TC22		TC22C	
			mm Unit	inch Unit	mm Unit	inch Unit
Turning Holder	O.D Holder	Extension (40mm)	Opt.	Opt.	1	1
	Facing Holder		1	1	1	1
Boring Holder	I.D Holder	Single (Ø40, Ø1 1/2")	5	5	4	4
	U-Drill Holder	Cap	1	1	1	1
Driven Holder	Straight Mill Holder	Standard	-	-	-	-
		TTC	-	-	-	-
	Angular Mill Holder	Standard	-	-	-	-
		TTC	-	-	-	-
Socket	Boring	Ø10 (Ø3/8")	1	-	1	-
		Ø12 (Ø1/2")	1	1	1	1
		Ø16 (Ø5/8")	1	-	1	-
		Ø20 (Ø3/4")	1	1	1	1
		Ø25 (Ø1")	1	1	1	1
		Ø32 (Ø1 1/4")	1	1	1	1
	Drill	MT 1 × MT 2	1	1	1	1
		MT 2	1	1	1	1
	ER Collet		-	-	-	-

Specifications are subject to change without notice for improvement.

SPECIFICATIONS

Tooling System

unit : mm(in)

TC22M/MC

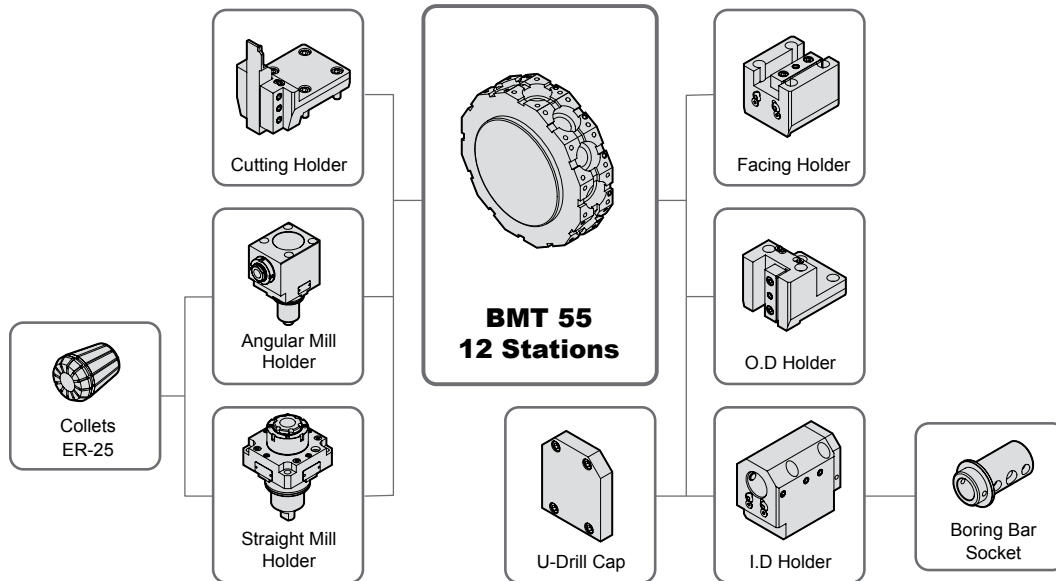

Tooling Parts Detail

ITEM			TC22M		TC22MC	
			mm Unit	inch Unit	mm Unit	inch Unit
Turning Holder	O.D Holder	Right/Left	4	4	4	4
	Cutting Holder		1	1	1	1
	Facing Holder		1	1	1	1
Boring Holder	I.D Holder	Single (Ø40, Ø1 1/2")	4	4	4	4
	U-Drill Holder	Cap	1	1	1	1
Driven Holder	Straight Mill Holder	Standard	1	1	1	1
		TTC	Opt.	Opt.	Opt.	Opt.
	Angular Mill Holder	Standard	1	1	1	1
		TTC	Opt.	Opt.	Opt.	Opt.
Socket	Boring	Ø10 (Ø3/8")	1	1	1	1
		Ø12 (Ø1/2")	1	1	1	1
		Ø16 (Ø5/8")	1	1	1	1
		Ø20 (Ø3/4")	1	1	1	1
		Ø25 (Ø1")	1	1	1	1
		Ø32 (Ø1 1/4")	1	1	1	1
	Drill	MT 1 × MT 2	Opt.	Opt.	Opt.	Opt.
		MT 2	Opt.	Opt.	Opt.	Opt.
		MT 3	Opt.	Opt.	Opt.	Opt.
	ER Collet		1 Set	1 Set	1 Set	1 Set

SPECIFICATIONS

Tooling Travel Range

unit : mm(in)

TC22

O.D Tool Holder

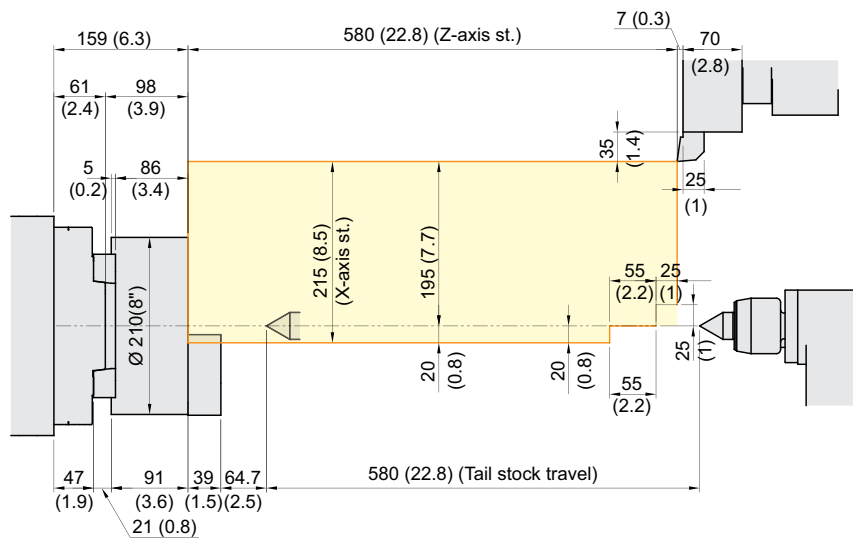

I.D Tool Holder

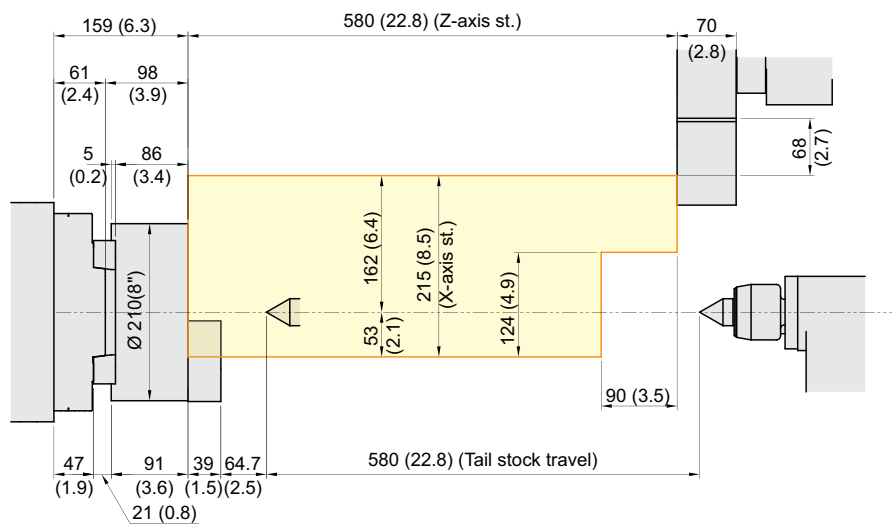

SPECIFICATIONS

Tooling Travel Range

unit : mm(in)

TC22C

O.D Tool Holder

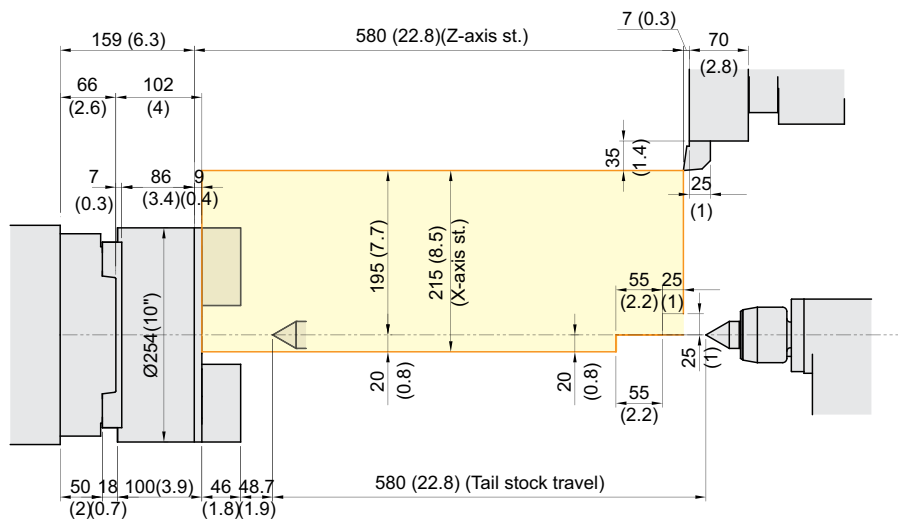

I.D Tool Holder

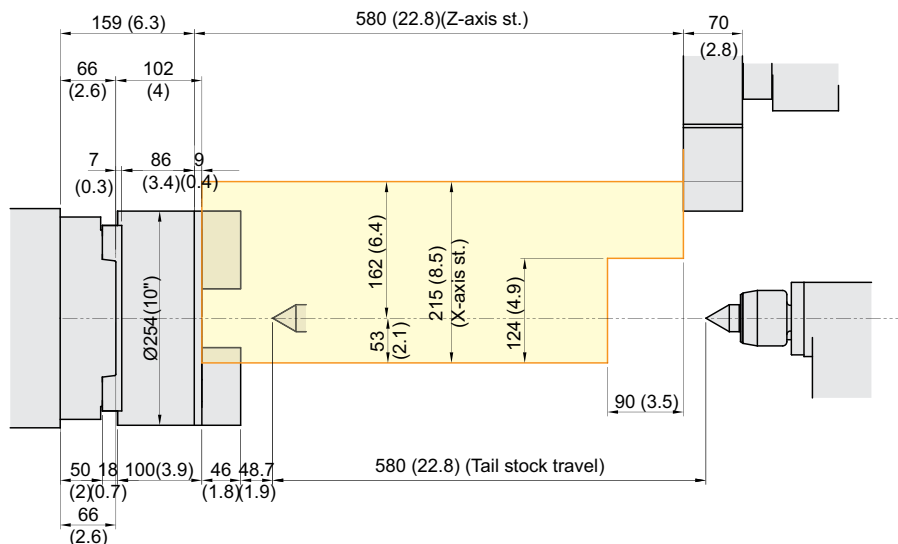

SPECIFICATIONS

Tooling Travel Range

unit : mm(in)

TC22M

O.D. Tool holder

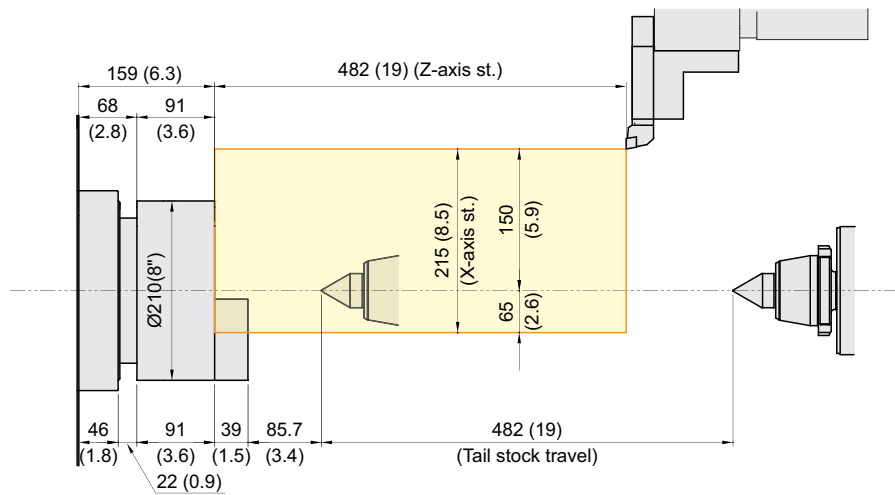

I.D. Tool holder

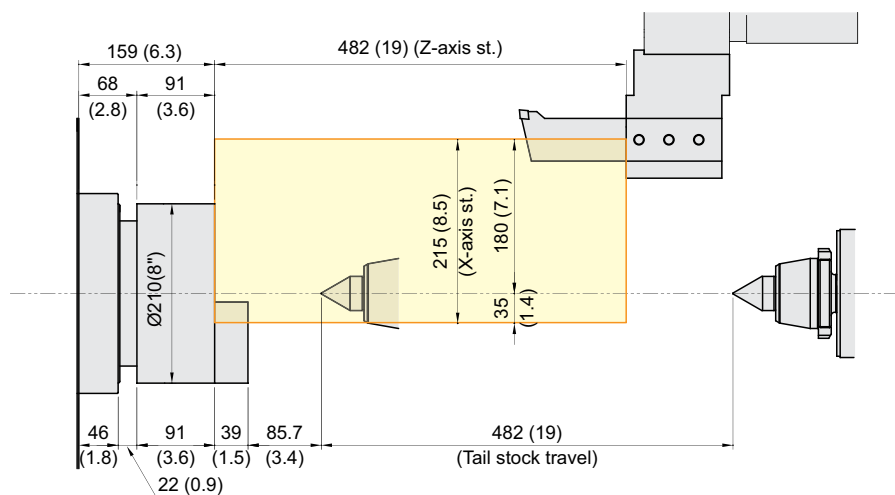

SPECIFICATIONS

Tooling Travel Range

unit : mm(in)

TC22M

Straight Mill Holder

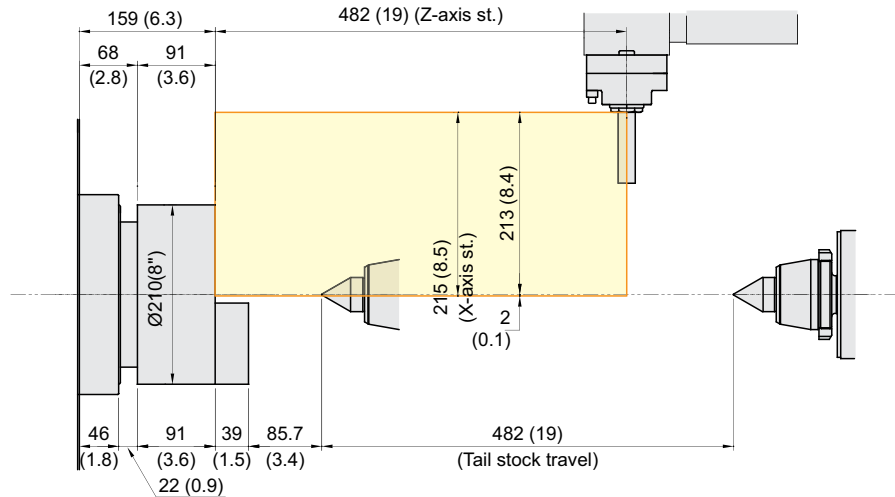

Angular Mill Holder

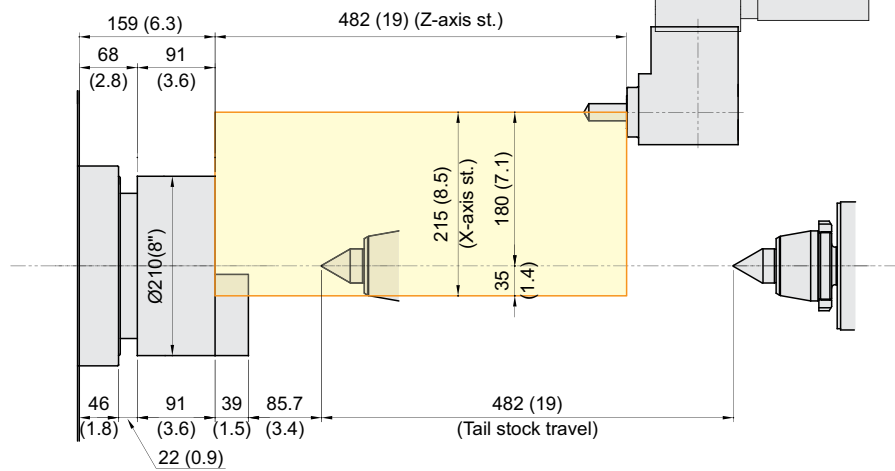

Face Tool holder

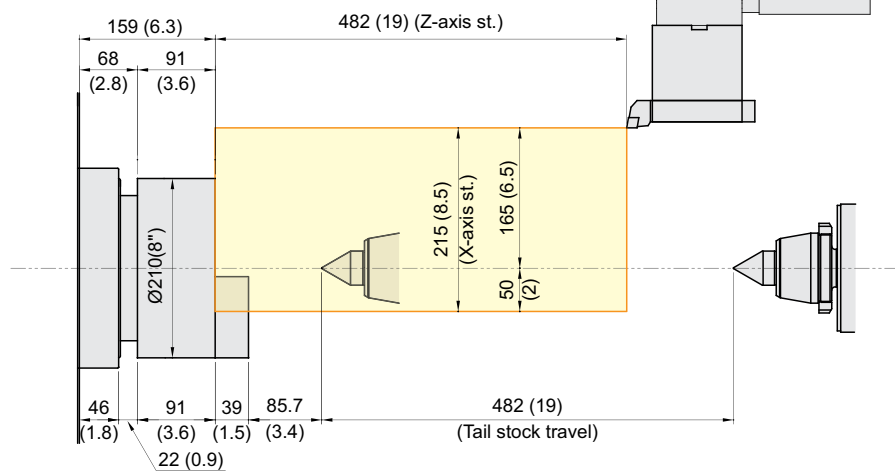

SPECIFICATIONS

Tooling Travel Range

unit : mm(in)

TC22MC

O.D. Tool holder

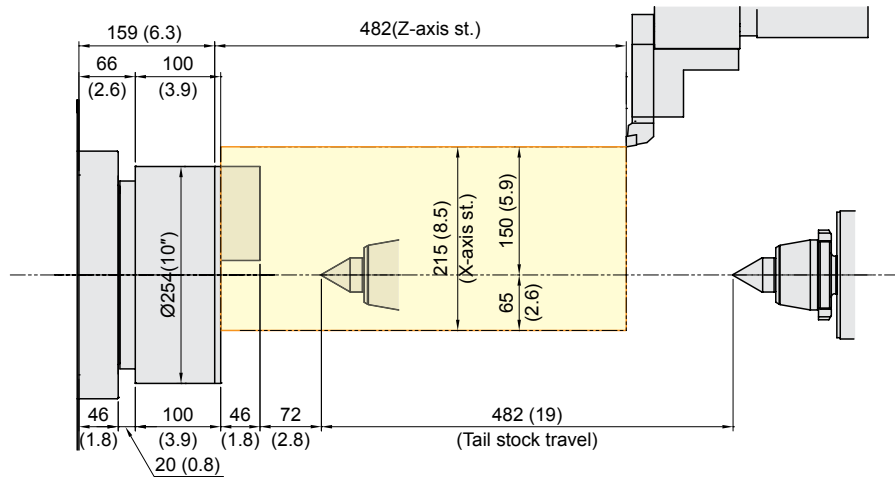

I.D. Tool holder

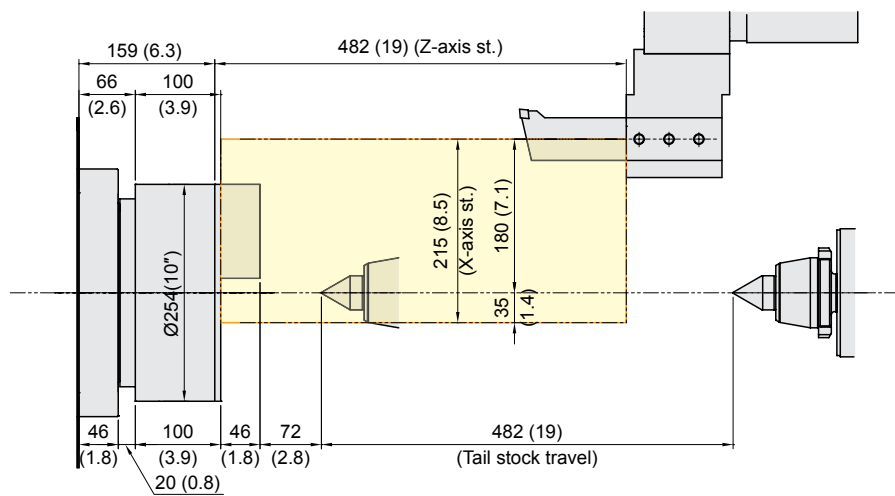

SPECIFICATIONS

Specifications

[] : Option

ITEM		TC22	TC22C	
CAPACITY	Swing Over the Bed	mm(in)	Ø550 (21.7")	
	Swing Over the Carriage	mm(in)	Ø390 (15.4")	
	Max. Turning Dia.	mm(in)	Ø380 (15")	
	Max. Turning Length	mm(in)	565 (22.2")	550 (21.7")
	Bar Capacity	mm(in)	Ø65 (2.6")	Ø81 (3.2")
SPINDLE	Chuck Size	inch	8" [10"]	10"
	Spindle Bore	mm(in)	Ø76 (3")	Ø92 (3.6")
	Spindle Speed (rpm)	r/min	4,500 [4,000] [4,000]	3,500
	Motor (Max/Cont.)	kW(HP)	18.5/15 (25/20) [18.5/15 (25/20)] [23.6/15 (31.6/20)]	18.5/15 (25/20)
	Torque (Max/Cont.)	N·m(lbf·ft)	206/125.3 (151.9/92.4) [353.2/214.8 (260.5/158.4)] [225/143.2 (166/105.6)]	403.6/245.4(297.7/181)
	Spindle Type	-	BELT	
	Spindle Nose	-	A2-6	A2-8
	C-axis Indexing	deg	-	
FEED	Travel (X/Z/B)	mm(in)	215/580 (8.5"/22.8")	
	Rapid Traverse Rate (X/Z)	m/min(ipm)	24/30 (945/1,181)	
	Slide Type	-	BOX GUIDE	
TURRET	No. of Tools	EA	12	
	Tool Size	OD	mm(in)	□25 (1")
		ID	mm(in)	Ø40 (1.6")
	Indexing Time	sec/step	0.12	
LIVE TOOL	Motor (Max/Cont.)	kW(HP)	-	
	Milling Tool Speed (rpm)	r/min	-	
	Torque (Max/Cont.)	N·m(lbf·ft)	-	
	Collet Size	mm(in)	-	
	Type	-	-	
TAIL STOCK	Taper	-	MT#4 [MT#5]	
	Quill Dia.	mm(in)	Ø65 (2.6") [Ø100 (3.9")]	
	Quill Travel	mm(in)	80 (3.1") [120 (4.7")]	
	Travel	mm(in)	580 (22.8")	
TANK CAPACITY	Coolant Tank	ℓ (gal)	150 (39.6)	
	Lubricating Tank	ℓ (gal)	1.8 (0.5)	
POWER SUPPLY	Electric Power Supply	kVA	23	
	Thickness of Power Cable	mm ²	OVER 16	
	Voltage	V/Hz	220/60 (200/50*)	
MACHINE	Floor Space (L×W)	mm(in)	2,925×1,650 (115.2"×65")	3,024×1,650 (119"×65")
	Height	mm(in)	1,820 (71.7")	
	Weight	kg(lb)	4,100 (9,039)	4,200 (9,259)
NC	Controller	-	FANUC - Smart Plus [SIEMENS 828D]	FANUC - Smart Plus

◆ The tailstock travel of 580mm is based on a standard manual tailstock. Due to the different reference positions, please ask sales person for option tailstocks such as programmable tailstock.

*) Using 50Hz voltage instead of 60Hz may lower the output of motors. (excluding servo motors and inverter motors)

Specifications are subject to change without notice for improvement.

SPECIFICATIONS

Specifications

[] : Option

ITEM		TC22M	TC22MC
CAPACITY	Swing Over the Bed	Ø550 (21.7")	
	Swing Over the Carriage	Ø390 (15.4")	
	Max. Turning Dia.	Ø300 (11.8")	
	Max. Turning Length	467 (18.4")	452 (17.8")
	Bar Capacity	Ø65 (2.6")	Ø81 (3.2")
SPINDLE	Chuck Size	8" [10"]	
	Spindle Bore	Ø76 (3")	
	Spindle Speed (rpm)	4,500 [4,000] [4,000]	
	Motor (Max/Cont.)	18.5/15 (24.8/20.1) [18.5/15 (24.8/20.1)] [23.6/15 (31.6/20.1)]	
	Torque (Max/Cont.)	206/125.3 (151.9/92.4) [353.2/214.8 (260.5/158.4)] [225/143.2 (166/105.6)]	
	Spindle Type	BELT	
	Spindle Nose	A2-6	
	C-axis Indexing	0.001°	
FEED	Travel (X/Z/B)	215/482 (8.5"/19")	
	Rapid Traverse Rate (X/Z)	24/30 (945/1,181)	
	Slide Type	BOX GUIDE	
TURRET	No. of Tools	12	
	Tool Size	OD	□ 25 (1")
		ID	Ø40 (1.6")
	Indexing Time	0.2	
LIVE TOOL	Motor (Max/Cont.)	5.5/3.7 (7.5/5) [5.3/2.8 (7.1/3.8)]	
	Milling Tool Speed (rpm)	6,000 [6,000]	
	Torque (Max/Cont.)	52.5/26.5 (38.7/19.5) [51/26.8 (37.6/19.8)]	
	Collet Size	Ø16 (0.6") : ER25	
	Type	BMT55	
TAIL STOCK	Taper	MT#4 [MT#5]	
	Quill Dia.	Ø65 (2.6") [Ø100 (3.9")]	
	Quill Travel	80 (3.1") [120 (4.7")]	
	Travel	482 (19")	
TANK CAPACITY	Coolant Tank	150 (39.6)	
	Lubricating Tank	1.8 (0.5)	
POWER SUPPLY	Electric Power Supply	23	
	Thickness of Power Cable	OVER 16	
	Voltage	220/60 (200/50*)	
MACHINE	Floor Space (L×W)	2,925×1,650 (115.2"×65")	3,024×1,650 (119"×65")
	Height	1,820 (71.7")	
	Weight	4,200 (9,259)	4,300 (9,480)
NC	Controller	FANUC - Smart Plus [SIEMENS 828D]	

❖ The tailstock travel of 482mm is based on a standard manual tailstock. Due to the different reference positions, please ask sales person for option tailstocks such as programmable tailstock.

*) Using 50Hz voltage instead of 60Hz may lower the output of motors. (excluding servo motors and inverter motors)

Specifications are subject to change without notice for improvement.

CONTROLLER

FANUC – Smart Plus

[] : Option

Controlled axis / Display / Accuracy Compensation	
Control axis	2 axis (X, Z) / 3 axis (X, Z, C) / 4 axis (X, Z, Y, C) 5 axis (X, Z, B, C, A) / 6 axis (X, Z, Y, B, C, A) 7 axis (X1/Z1, X2/Z2, B2, C1/C2)
Simultaneously controlled axis	2 axis [Max. 4 axis]
Designation of spindle axis	3 axis [Max. 4 axis]
Least setting Unit	X, Z, Y, B axis : 0.001 mm (0.0001 inch) C, A axis : 0.001 deg
Least input increment	X, Z, Y, B axis : 0.001 mm (0.0001 inch) C, A axis : 0.001 deg
Inch / Metric conversion	G20 / G21
High response vector control	
Interlock	All axis / Each axis
Machine lock	All axis
Backlash compensation	± 0~9999 pulses (exc. Rapid traverse / Cutting feed)
Position switch	
LCD / MDI	15 inch LCD unit (with Touch Panel)
Feedback	Absolute motor feedback
Stored stroke check 1	Over travel
Stored stroke check 2, 3	
PMC axis control	
Operation	
Automatic operation (Memory)	
MDI operation	
DNC operation	Needed DNC software / CF card
Program restart	
Wrong operation prevention	
Program check function	Dry run
Single block	
Search function	Program Number / Sequence Number
Interpolation functions	
Pano interpolation	
Positioning	G00
Linear interpolation	G01
Circular interpolation	G02, G03
Exact stop mode	Single : G09, Continuous : G61
Dwell	G04, 0 ~ 9999.9999 sec
Skip	G31
Reference position return	1st reference : G28, 2nd reference : G30 Ref. position check : G27
Thread synchronous cutting	G33
Thread cutting retract	
Variable lead thread cutting	
Multi / Continuous threading	
Feed function / Acc. & Dec. control	
Manual feed	Rapid traverse Jog : 0~2,000 mm/min (79 ipm) Manual handle : x1, x10, x100 pulses Reference position return
Cutting Feed command	Direct input F code
Feedrate override	0 ~ 200% (10% Unit)
Rapid traverse override	1%, F25%, 50%, 100%
Override cancel	
Feed per minute	G98
Feed per revolution	G99
Look-ahead block	1 block
Program input	
Tape Code	EIA / ISO
Optional block skip	9 ea
Program stop / end	M00, M01 / M02, M30
Maximum command unit	± 999,999.999 mm (± 99,999.9999 inch)
Plane selection	X-Y : G17 / Z-X : G18 / Y-Z : G19
Workpiece coordinate system	G52, G53, 6 pairs (G54 ~ G59)
Manual absolute	Fixed ON
Programmable data input	G10
Sub program call	10 folds nested
Custom macro	#100 ~ #199, #500 ~ #999
G code system	A, B/C
Programmable mirror image	G51.1, G50.1
G code preventing buffering	G4.1
Direct drawing dimension program	Including Chamfering / Corner R
Conversational Program	SmartGuide-i

Program input	
Multiple repetitive cycles	1, 11
Canned cycle for turning	
Auxiliary function / Spindle speed function	
Auxiliary function	M & 4 digit
Level-up M Code	High speed / Multi / Bypass M code
Spindle speed function	S & 5 digit, Binary output
Spindle override	0% ~ 150% (10% Unit)
Multi position spindle orientation	M19 (S##)
Rigid tapping	
Constant surface speed control	G96, G97
Tool function / Tool compensation	
Tool function	T & 2 digit + Offset 2 digit
Tool life management	
Tool offset pairs	128 pairs
Tool nose radius compensation	G40, G41, G42
Geometry / Wear compensation	
Direct input of offset measured B	
Editing function	
Part program storage size	5,120m (2MB)
No. of registerable programs	1,000 ea
Program protect	
Background editing	
Extended part program editing	Copy, move and change of NC program
Memory card program edit	
Data input / output & Interface	
I/O interface	CF card, USB memory Embedded Ethernet interface
Screen hard copy	
External message	
External key input	
External workpiece number search	
Automatic data backup	
Setting, display and diagnosis	
Self-diagnosis function	
History display & Operation	Alarm & Operator message & Operation
Run hour / Parts count display	
Maintenance information	
Actual cutting feedrate display	
Display of spindle speed / T code	
Graphic display	
Operating monitor screen	Spindle / Servo load etc.
Power consumption monitoring	Spindle & Servo
Spindle / Servo setting screen	
Multi language display	Support 24 languages
Display language switching	Selection of 5 optional Languages
LCD Screen Saver	Screen saver
Unexpected disturbance torque	BST (Back spin torque limit)
Function for machine type	
Cs contour control (C & A axis)	Mill, MS, Y, SY, LF-Mill, TTMS, TTSY
Polar coordinate interpolation	Mill, MS, Y, SY, LF-Mill, TTMS, TTSY
Cylindrical interpolation	Mill, MS, Y, SY, LF-Mill, TTMS, TTSY
Polygon turning (2 Spindles)	Mill, MS, Y, SY, LF-Mill, TTMS, TTSY
Canned cycle for drilling	Mill, MS, Y, SY, LF-Mill, TTMS, TTSY
Spindle orientation expansion	MS, SY TTS, TTMS, TTSY
Spindle synchronous control	MS, SY TTS, TTMS, TTSY
Torque control	MS, SY TTS, TTMS, TTSY
Y axis offset	Y, SY, TTSY
Arbitrary angular control	Y, SY, TTSY
Composite / Superimposed control	MS, SY, TTS, TTMS, TTSY
Balance cutting	TTS, TTMS, TTSY
Option	
Fast ethernet	Needed option board
Data server	Needed option board
Protection of data at 8 levels	
Tool offset pairs	200 pairs
Helical interpolation	
Optional block skip	40 ea, 200 ea (AICC 11)

Figures in inch are converted from metric values.

The FANUC controller specifications are subject to change based on the policy of company CNC supplying.

CONTROLLER

SIEMENS 828D

[] : Option ☆ Needed technical consultation

Controlled axis / Display / Accuracy Compensation

Control axis	2 axis (X, Z) – Std.
	3 axis (X, Z, C) – Mill
	4 axis (X, Z, Y, C) – Y
	5 axis (X, Z, B, C, A) – MS
	6 axis (X, Z, Y, B, C, A) – SY
	Max. 4 axis
Simultaneously controlled axis	Max. 4 axis
Least setting Unit	X, Z, Y, B axis : 0.001 mm (0.0001 inch)
	C, A axis : 1 deg [0.001] deg
Least input increment	X, Z, Y, B axis : 0.001 mm (0.0001 inch)
	C, A axis : 1 deg [0.001] deg
Inch / Metric changeover	G70 (inch) / G71 (metric)
Interlock	All axis / Each axis
Backlash compensation	
Pitch error compensation	Leadscrew pitch error compensation
LCD / MDI	10.4 inch color LCD [15 inch color LCD (With Touch panel)]
Keyboard	QWERTY full keyboard
Stored stroke check	Over travel

Operation

Automatic operation	
MDI operation	
Program restart	
Program check function	Dry run / Program check / Machine lock
Single block	
Block search	Block search
Reposition	
Working area limit	Working area limitations

Interpolation functions

Positioning	G00
Linear interpolation	G01
Circular interpolation	Circular interpolation CW (G02)
	Circular interpolation CCW (G03)
Exact position stop	Single block exact stop (G09)
	Exact stop G60 (G601, G602, G603)
Dwell	Dwell (G04)
Reference position return	Return to reference point
	Return to 2nd reference point
Helical interpolation	
Thread synchronous cutting	
Thread cutting retract	
Spline interpolation	Non-uniform rational B splines

Feed function / Acc. & Dec. control

Manual feed	Rapid traverse
	Jog
	Manual handle
	Reference position return
Cutting feed command	Direct input F code
Feedrate override	0 ~ 200% (10% Unit)
Rapid traverse override	1%, 25%, 50%, 100%
Feed per minute	G94
Feed per revolution	G95
Look-ahead block	1 block

Program input

ISO support	G291 (ISO) / G290
	(ISO G Code system-A)
Optional block skip	2
Program stop / end	M00, M01 / M02, M30
Maximum command unit	± 999,999,999 mm, ± 99,999,9999 inch
Plane selection	X-Y : G17, X-Z : G18, Y-Z : G19 G54 ~ G57, G505~G549
Workpiece coordinate system	G500 (Basic frame – settable zero offset)
	G53 (Work offset non modal)
	G153 (basic frame non modal)
Sub program call	11 folds nested
G code preventing buffering	STOPRE
Turning cycle	Turning programming (Cycle 93, 94, 95, 97)
User cycle	
3D simulation	
Real time simulation	
Shop Turn	Machining step programming for turning

Auxiliary function / Spindle speed function

Auxiliary function	M Code 4 digit
Spindle speed function	S Code 5 digit
Spindle override	0% ~ 150% (10% Unit)
Spindle orientation	SPOS
Rigid tapping	
Automatic mode interchange	Spindle / Axis mode
Constant surface speed control	G96, G97
Spindle speed limitation	LIMS

Tool function / Tool compensation

Tool function	Tool number & Tool name Tool : T + Offset : D
Tool life management	128 ea : Std. 256 ea : Mill 768 ea : Y, MS, SY 256 ea : Std. 512 ea : Mill 1,536 ea : Y, MS, SY
Tools in tool list	
Cutting Edges in tool list	
Tool nose radius compensation	ISO (G40, G41, G42)
Geometry / Wear compensation	
Measurement of tool length	
Tool management function	

Editing function

Part program storage size	3MB – Std. 5MB – Mill 10MB – Y, MS, SY
No. of registerable programs	750 ea
External Storage devices	Local network, Server, USB, Flash drive
Background editing	
Extended part program editing	Copy, move and change of NC program
Memory card program edit	

Data input / output & Interface

I/O interface	CF card interface (ONLY 10.4") USB memory interface Embedded Ethernet memory interface
---------------	--

Screenshot

Setting, display and diagnosis

Self-diagnosis function	
History display & Operation	Alarm & Operator message & Operation
Run hour / Parts count display	
Maintenance information	
Actual cutting feedrate display	
Display of spindle speed / T code	
Graphic display	
Operating monitor screen	Spindle / Servo load etc. Support 9 languages Chinese (Simplified/Traditional), English, French, German, Italian, Korean, Portuguese, Spanish [☆ Support 22 languages : Inquiry need]
Multi language display	
LCD Screen Saver	Screen saver & Motion sensing

Function for machine type

Cs contour control (C & A axis)	Mill, MS, Y, SY model
Polar coordinate interpolation	Mill, MS, Y, SY model
Cylindrical interpolation	Mill, MS, Y, SY model
Canned cycle for drilling	Mill, MS, Y, SY model
[Polygon turning (CP-Basic)]	Mill, MS, Y, SY model
[Hobbing / Skybing (CP-Comfort)]	Mill, MS, Y, SY model
Spindle synchronous control	MS, SY model
Servo tailstock function	MS, SY model

Option

Additional optional block skip	10
Contour handwheel	